

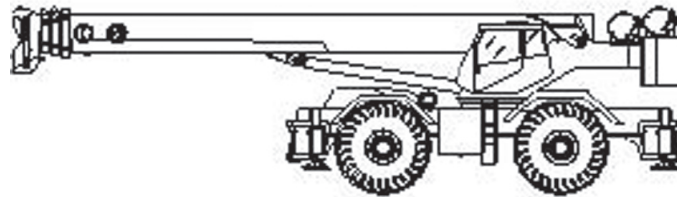

Rough Terrain Crane Specifications

RT500-1 Series



STANDARD BOOM EQUIPMENT

BOOM

35-110' (10.67-33.53 m), four section full power boom. Telescoping is mechanically synchronized with single lever control. The synchronization system consists of a single telescope cylinder and high strength leaf chains to extend and retract the third section and the tip section. The boom is a high-strength four plate design, welded inside and out with anti-friction slide pads. Boom side plates are made with stamped impressions to reduce weight and increase strength.

BOOM HEAD

Welded to fourth section of boom. Five or six metallic load sheaves and two idler sheaves mounted on heavy duty, anti-friction bearings. Quick reeving boom head. Provision made for side-stow jib mounting.

OPTIONAL BOOM EQUIPMENT

JIBS

Jibs feature easy installation/stowage through use of spear type stowage system. Jibs utilize a single metallic sheave mounted on anti-friction bearing. Jibs are quickly offsettable at 0°, 15° or 30° by relocating two pins. 32' (9.68 m) side stow swing-on one piece lattice type jib. Maximum tip height is 146' (44.5 m), 33-37' (10.15-17.30 m) side stow swing-on lattice type jib. Jib is extendable to 57' (17.30 m) by means of a 25' (7.62 m) manual pull-out tip section, roller supported for ease of extension. Maximum tip height is 170' (51.82 m). Stub head allows removal of pull-out from 33-57' jib, allowing it to function as a 32' swing-on with improved chart at longer radii when extra jib length is not required.

A single boom hoist cylinder provides for boom elevation of -4 to 76°. Maximum tip height 115' (35.05 m).

AUXILIARY BOOM HEAD

Removable auxiliary boom head has single metallic sheave mounted on anti-friction bearing. Removable pin-type rope guard for quick reeving. Installs on main boom peak only. Removable is not required for jib use.

HOOK BLOCK

Five or six metallic sheaves on anti-friction bearings with hook and hook latch. Quick reeving design does not require removal of wedge and socket from rope.

HOOK AND BALL

7 ton (6.3 mt) top swivel ball with hook and hook latch.

STANDARD UPPERSTRUCTURE EQUIPMENT
UPPERSTRUCTURE FRAME

All welded one-piece structure fabricated with high tensile strength alloy steel. Counterweight is bolted to frame.

TURNTABLE CONNECTION

Swing bearing is a single row, ball type, with internal teeth. The swing bearing is bolted to the revolving upperstructure and to the carrier frame.

SWING

A hydraulic motor drives a double planetary reduction gear for precise and smooth swing function. Swing speed (no load) is two rpm.

SWING BRAKE

Heavy duty multiple disc swing brake is mechanically actuated from operator's cab by foot pedal. Brake may be locked on or used as a momentary brake. Air operated 360° mechanical house lock is standard.

RATED CAPACITY INDICATOR

Rated Capacity Indicator with visual and audible warning system and automatic function disconnects. Second generation pictographic display includes: boom radius, boom angle, boom length, allowable load, actual load and percentage of allowable load registered by bar graph. Operator settable alarms provided for swing angle, boom length, boom angle, tip height and work area exclusion zone. Anti-two block system includes audio/visual warning and automatic function disconnects.

OPERATORS CAB

Environmental cab with all steel construction, optimum visibility, tinted safety glass throughout and rubber floor matting is mounted on vibration absorbing pads. The cab has a sliding door on the left side, framed sliding window on the right side, hinged tinted all glass skylight and removable front windshield to provide optimum visibility of the load open or closed. Acoustical foam padding insulates against sound and weather. The deluxe six-way adjustable seat is equipped with a mechanical suspension and includes head and arm rests.

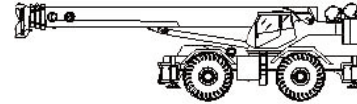
CONTROLS

All control levers and pedals are positioned for efficient operation. Armrest mounted dual axis controls for winch(s), swing, and boom elevation, winch rotation indication incorporated into control handles. Armrest swings up to improve access and egress. Vernier adjustable hand throttle included. Steering column mounted turn signal, wiper, and shift controls. Winches include ignition, engine stop, lights, horn, roof window wiper, hot air defroster, steering mode, parking brake, outriggers, 360° house lock. Horn and winch speed shift switches are mounted in the levers. Foot control pedals include swing brake, boom telescope, service brake and accelerator.

INSTRUMENTATION AND ACCESSORIES

In-cab gauges include air pressure, bubble level, engine oil pressure, fuel, engine temperature, voltmeter, transmission temperature and transmission oil pressure. Indicators include low air, high water temperature, low oil pressure, high transmission temperature and low coolant level audio/visual warning, hoist drum rotation indicator(s) and Rated Capacity Indicator. Accessories include fire extinguisher; light package including headlights, tail light, brake lights, directional signals, four-way hazard flashers, dome light and back-up lights with audible back-up alarm; windshield washer/wiper; skylight wipers; R.H. and L.H. rear view mirrors; dash lights; and seat belt. Circuit breakers protect electrical circuits.

HYDRAULIC CONTROL VALVES

Valves are mounted on the rear of the upperstructure and are easily accessible. Valves have electric/hydraulic operators and include one pressure compensated two spool valve for main and auxiliary winch, and one single spool valve for swing. Quick disconnects are provided for ease of installation of pressure check gauges

OPTIONAL EQUIPMENT

Auxiliary Winch, Heater/Defroster, hydraulically powered Air Conditioner with or without hydraulic heater, LP or Diesel Heater/Defroster, Tachometer, Work Lights, Rotating Beacon

STANDARD CARRIER EQUIPMENT
CARRIER CHASSIS

Chassis is Terex designed with four-wheel drive and four-wheel steer (4X4X4). Has box-type construction with reinforcing cross members, a precision machined turn table mounting plate and integrally welded outrigger boxers. Decking has anti-skid surfaces, including between the frame rails lockable front tool storage compartment and access steps and handles on the left and right sides and on all four corners.

AXLES AND SUSPENSION

Rear axle is a planetary drive/steer type with 10.5" (0.26 m) of total oscillation. Automatic oscillation lockouts that engage when the superstructure is swung 10° in either direction. Front axle is a planetary drive/steer type, rigid mounted to the frame for increased stability.

STEERING

Hydraulic four-wheel full power steering for two-wheel, four-wheel coordinated, or four-wheel crab steer is easily controlled by steering wheel. A rear axle centering light is provided. Turning radius to center of outside tire.

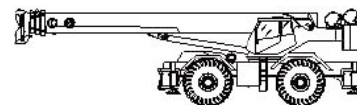

	Turning Radius: (to CL of outside tire)	Curb Clearance Radius
Two-wheel:	40' 4" (12.3 m)	40' (12.2 m)
Four-wheel:	23' 4" (7.1 m)	23' (7 m)

TRANSMISSION

Range-shift type power-shift transmission with integral torque converter has neutral safety start, six speeds forward and six speeds reverse provides wide ratio coverage. Automatic pulsating back-up alarm.

STANDARD CARRIER EQUIPMENT (CONTINUED)

**MULTI-POSITION OUT AND DOWN
OUTRIGGERS**

Fully independent hydraulic outriggers may be utilized fully extended to 22' (6.71 m) centerline to centerline, in their 1/2 extended position, or fully retracted for maximum flexibility. Easily removable aluminum floats, each with an area of 452 in² (2 919 cm²), stow on the outrigger boxes at their point of use. Complete controls and a sight leveling bubble are located in the operator's cab.

WHEELS AND TIRES

Disk type wheels with full tapered bead seat rim. 150.5" (3.82 m) wheelbase.

TIRES

Wide earthmover (E3) style tread tires provide life and flotation.
26.5x25, 26 P.R. – std.
21x25, 28 P.R. – opt.

SERVICE BRAKES

Split system air over hydraulic brakes on all four wheels, 18.5" diameter disc dual caliper brakes on front wheels and single caliper brakes on rear axle.

PARKING BRAKE

Front axle equipped with spring-set, air released emergency/parking brake.

OPTIONAL EQUIPMENT

Immersion Heater, Pintle Hook(s), Clearance Lights, Independent Rear Steering, Four Mode Rear Wheel Steer, 20,000 lb line pull front mounted winch.

HYDRAULIC SYSTEM

HYDRAULIC PUMPS

Three gear type pumps, one in single and two tandem pumps, driven off the transmission. Combined system capability is 147 gpm (557 lpm). Includes pump disconnect on winch and tandem pump.

- ▶ **Main winch pump**
- ▶ 55.3 gpm (209.3 lpm) @ 3,500 psi (246.1 kg/cm²)
- ▶ **Boom Hoist and Telescope Pump**
- ▶ 39.1 gpm (148 lpm) @ 3,500 psi (246.1 kg/cm²)
- ▶ **Power Steering, Outrigger and Winch Boost Pump**
- ▶ 19.6 gpm (74.2 lpm) @ 2,500 psi (175 kg/cm²)

FILTRATION

Full flow oil filtration system with bypass protection includes a removable 60 mesh (250 micron) suction screen-type filter and five micron replaceable return line filter.

HYDRAULIC RESERVOIR

All steel, welded construction with internal baffles and a diffuser. Provides easy access to filters and is equipped with an external sight level gauge. The hydraulic tank is pressurized to aid in keeping out contaminants and in reducing potential pump cavitation. Capacity is 112 gal (424 L). Hydraulic oil cooler is standard.

MAIN WINCH SPECIFICATIONS

Hydraulic winch with bent axis piston and planetary reduction gearing provides two-speed operation with equal speeds for power up and down. Winch is equipped with an integral automatic brake, grooved drum, tapered flanges, standard cable roller on drum, and an electric drum rotation indicator.

Performance	LO-Range	HI-Range
▶ Max line speed (no load)		
▶ First Layer	171 fpm (52.21 m/min)	343 fpm (104.5 m/min)
▶ Fifth Layer	248 fpm (75.6 m/min)	496 fpm (151.2 m/min)
<hr/>		
▶ Max. line pull-first layer	15,639 lb (7 093 kg)	7,298 lb (3 310 kg)
▶ Max. line pull-fifth layer	10,827 lb (4 911 kg)	5,052 lb (2 291 kg)
▶ Permissible line pull	11,250 lb (5 102 kg)	

Drum Dimensions	Drum Capacity
▶ 10.62" (270 mm) drum diameter	Max. Storage: 939' (286.2 m)
▶ 22.42" (570 mm) length	7th layer not a working layer
▶ 20" (508 mm) flange dia.	Max. Useable: 772' (235.3 m)*
▶ Cable: 5/8" x 500' (16 mm x 152.4 m)	
▶ Cable type: 5/8" x (16 mm) 6x19 IWRC,	
▶ XIPS, right regular lay, performed	
*Based on minimum flange height above top layer to comply with ANSI B30.5	

OPTIONAL AUXILIARY WINCH

Hydraulic 2-speed winch with bent axis piston motor, equal speed power up and down, planetary reduction with integral automatic brake, grooved drum with tapered flanges, drum roller, and rotation indicator.

Performance	
▶ Max. line speed (no load) Fifth layer	496 fpm (151.2 m/min)
▶ Max. line pull First layer	15,639 lb (7 093 kg)

Drum Dimensions and Capacity (Same as main winch)

OPTIONAL HOIST LINE

Main winch and optional auxiliary winch: 5/8" (16 mm) rotation resistant compacted strand 34x7. Min breaking strength 28.21 tons (25.59 mt)

ENGINE SPECIFICATIONS

- ▶ Make and Model Cummins QSB185
- ▶ Type 6 cylinder
- ▶ Bore and Stroke 4.02 x 4.72" (102x120 mm)
- ▶ Displacement 360 cubic inches (5.91)
- ▶ Rated HP 185 hp (138 kw) @ 2400 rpm
- ▶ Maximum HP 190 hp (142 kw) @ 2300 rpm
- ▶ Rated Torque 548 lb•ft(743 N•m) @ 1400 rpm
- ▶ Aspiration turbocharged & charge air cooled
- ▶ Air Filter dry type
- ▶ Electrical System 12 volt
- ▶ Alternator 100 amp
- ▶ Battery (2) 12V-1600 CCA
- ▶ Fuel Capacity 80 gal (303 L)

PERFORMANCE (STANDARD ENGINE)

Trans-mission Gear	Forward Drive	Max. Speed	Max. Tractive Effort	Grade-ability @ Stall
▶ Low 1	4-wheel	1.4 mph (2.7 kph)	102,809 lb (32 681 kg)	>100%
▶ Low 2	4-wheel	3.0 mph (6.0 kph)	49,473 lb (15 456 kg)	73.2%
▶ Low 3	4-wheel	8.2 mph (10.3 kph)	18,097 lb (8 909 kg)	20.7%
▶ High 1	2-wheel	4.2 mph (16.7 kph)	35,348 lb (5 525 kg)	45.7%
▶ High 2	2-wheel	8.8 mph (6.9 kph)	16,957 lb (13 226 kg)	19.2%
▶ High 3	2-wheel	22.8 mph (14.8 kph)	6,179 lb (6 250 kg)	5.6%

All performance data is based on a gross vehicle weight of 81,000 lb (36 741 kg). 26.5x25 tires, 4x4 drive. Performance may vary due to engine performance. Gradeability data is theoretical and is limited by tire slip, machine stability, or oil pan design.



GENERAL DIMENSIONS

1. Dimensions given assume the boom is fully retracted in travel position and 26.50 x 25 tires.

2. Minimum ground clearance under transmission: - 25.25"

axle bowls - 22.25"

tie rods - 25.5"

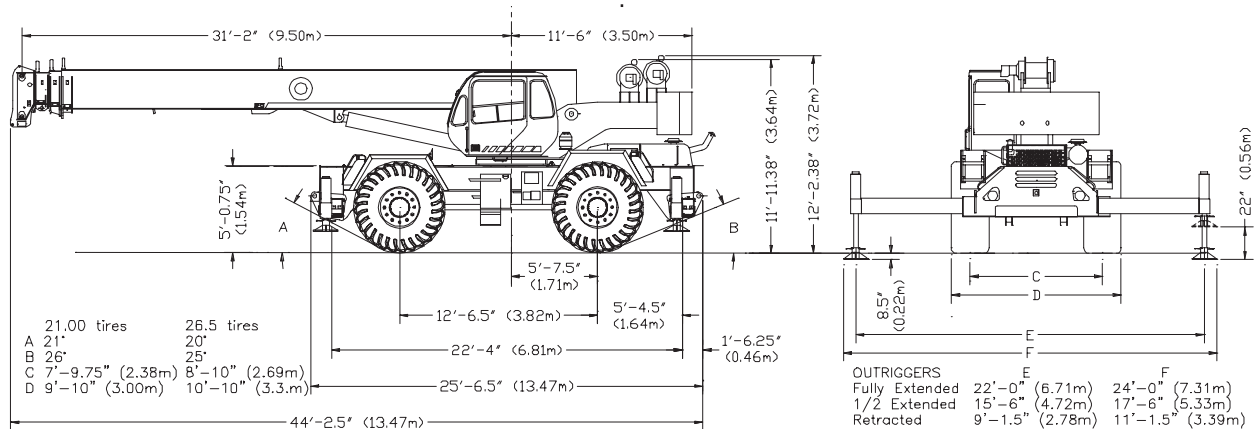

WEIGHTS & AXLE LOADS	GROSS WEIGHT LB	UPPER FACING FRONT		GROSS WEIGHT KG	UPPER FACING FRONT	
		FRONT	REAR		FRONT	REAR
Base Crane with 14,200 lb (6 440 kg) Counterweight	76,832	40,040	36,792	34,850	18,162	16,688
Add Options:						
32' (9.68 m) Swing-on Jib (Stowed)	+ 1,260	+ 2,130	- 870	+ 572	+ 966	- 394
33' - 57' (10.5 - 17.30 m) Swing-on Jib (Stowed)	+ 2,160	+ 3,600	- 1,440	+ 980	+ 1,633	- 653
Auxiliary Boom Head	+ 100	+ 300	- 230	+ 45	+ 136	- 91
Auxiliary Winch Controls and Plumbing Only	+ 75	+ 0	+ 75	+ 34	+ 0	+ 34
Auxiliary Winch with Wire Rope, Controls, Etc.	+ 264	- 60	+ 204	+ 120	- 27	+ 93
55T (49.9 mt) 6-Sheave Hook Block	+ 755	+ 1,130	- 375	+ 342	+ 512	- 170
55T (49.9 mt) 5-Sheave Hook Block	+ 723	+ 1,080	- 357	+ 328	+ 490	- 162
25T (22.7 mt) 2-Sheave Hook Block	+ 240	+ 290	- 50	+ 109	+ 130	- 21
7T (6.35 mt)	+ 580	+ 870	- 290	+ 263	+ 395	- 132
Pintle Hook:						
Front	+ 45	+ 60	- 15	+ 20	+ 27	+ 7
Rear	+ 45	- 25	+ 70	+ 20	- 11	- 31
Substitute:						
21.00x25 28 PR Tires	- 400	- 200	- 200	- 182	- 91	- 91
500' of 34x7 class spin resistant wire rope	+ 65	- 42	+ 107	+ 30	+ 19	+ 49

Note: Weights are for Terex supplied equipment and are subject to 2% variation due to manufacturing tolerances.